



**INSTALLATION  
AND  
OPERATING  
INSTRUCTIONS**

# Gas Griddles

**MODELS: GGT-24H, -36H, -48H**

**&**

**MODELS: GGM-24H, -36H, 48H**

(US & Canadian units are convertible and are assembled for Natural Gas)  
(European units are not convertible and assembled for the appropriate gas)

## IMPORTANT FOR FUTURE REFERENCE

Please complete this information and retain this manual for the life of the equipment. For Warranty Service and/or Parts, this information is required.

\_\_\_\_\_   
Model Number

\_\_\_\_\_   
Serial Number

\_\_\_\_\_   
Date Purchased



**FOR YOUR SAFETY:** Do not store or use gasoline or other flammable vapors and liquids in the vicinity of this or any other appliance.



**WARNING:** Improper installation, operation, service or maintenance can cause property damage, injury or death. Read and understand these instructions thoroughly before positioning, installing, maintaining or servicing this equipment.





P/N 88060-20 9-05



### APW WYOTT Foodservice Equipment Company



P.O. Box 1829  
Cheyenne, WY 82003



+1 (307) 634-5801 Phone  
+1 (307) 637-8071 Fax



+1 (800) 752-0863 Toll Free  
www.apwwyott.com

 **CAUTION:** These models are designed, built, and sold for commercial use. If these models are positioned so the general public can use the equipment, make sure that cautions, warnings, and operating instructions are clearly posted near each unit so that anyone using the equipment will use it correctly and not injure themselves or harm the equipment. 

 **WARNING:** Improper installation, adjustment, alteration, service or maintenance can cause property damage, injury or death. Read the installation, operating and maintenance instructions thoroughly before installing or servicing this equipment. 

 **WARNING:** Install per the spacing requirements listed in the installation section of this manual. We strongly recommend having a competent professional install the equipment. A licensed electrician should make the electrical connections and connect power to the unit. Local codes should always be used when connecting these units to electrical power. In the absence of local codes, use the latest version of the National Electrical Code. 



 **WARNING:** For your safety do not store or use gasoline or other flammable vapors and liquids in the vicinity of this or any other appliance. Keep the area free and clear of combustibles. (See ANZI Z83. 14B, 1991). 

 **NOTICE:** Instructions to be followed if anyone smells gas should be posted in a prominent place. These may be obtained from the gas supplier. 

### GAS PRESSURE

The appliance and it's individual shutoff valve must be disconnected from the gas supply piping system during any pressure testing of that system at test pressures in excess of ½ psi (3.45 kPa).

The appliance must be isolated from the gas supply piping system by closing it's individual manual shut-off valve during any pressure testing of the gas supply piping system at test pressures equal to or less than ½ psi (3.45 kPa).

 **WARNING:** A factory authorized agent should handle all maintenance and repair. Before doing any maintenance or repair, contact APW Wyott. 

Congratulations on your purchase of APW Wyott commercial cooking or refrigeration equipment. APW Wyott takes pride in the design and quality of our products. When used as intended and with proper care and maintenance, you will experience years of reliable operation from this equipment. To ensure best results, it is important that you read and follow the instructions in this manual carefully.

### TABLE OF CONTENTS:

ITEM	PAGE	ITEM	PAGE
Safety Precautions	3	Cleaning/Maintenance	7
Specifications & Dimensions	4	Service/Repair	7
General Installation Instructions	4	Troubleshooting	9
Lighting Instructions	5	Replacement Parts List & Exploded View	10
Operating Instructions	6	Warranty	12

### LOCATION OF DATA PLATE

The data plate is located on the back side of the front panel.

## IMMEDIATELY INSPECT FOR SHIPPING DAMAGE

All containers should be examined for damage before and during unloading. The freight carrier has assumed responsibility for its safe transit and delivery. If equipment is received damaged, either apparent or concealed, a claim must be made with the delivering carrier.

A) Apparent damage or loss must be noted on the freight bill at the time of delivery. It must then be signed by the carrier representative (Driver). If this is not done, the carrier may refuse the claim. The carrier can supply the necessary forms.

B) Concealed damage or loss if not apparent until after equipment is uncrated, a request for inspection must be made to the carrier within 15 days. The carrier should arrange an inspection. Be certain to hold all contents and packaging material.



Installation and start-up should be performed by a qualified installer who thoroughly read, understands and follows these instruction.



If you have questions concerning the installation, operation, maintenance or service of this product, write Technical Service Department APW Wyott Foodservice Equipment Company, P.O. Box 1829, Cheyenne, WY 82003.



## SAFETY PRECAUTIONS



Before installing and operating this equipment be sure everyone involved in its operation is fully trained and is aware of all precautions. Accidents & problems can result by a failure to follow fundamental rules and precautions.

The following words and symbols, found in this manual, alert you to hazards to the operator, service personnel or the equipment. The words are defined as follows:

 **DANGER:** This symbol warns of imminent hazard which will result in serious injury or death. 

 **WARNING:** This symbol refers to a potential hazard or unsafe practice, which could result in serious injury or death. 



 **CAUTION:** This symbol refers to a potential hazard or unsafe practice, which may result in minor or moderate injury or product or property damage. 



 **NOTICE:** This symbol refers to information that needs special attention or must be fully understood even though not dangerous. 



---

---

 **NOTICE:** This product is intended for commercial use only. Not for household use. 

 **CAUTION:** These models are designed, built, and sold for commercial use. If these models are positioned so the general public can use the equipment make sure that cautions, warnings, and operating instructions are clearly posted near each unit so that anyone using the equipment will use it correctly and not injure themselves or harm the equipment. 

 **WARNING: SHOCK HAZARD:** Do not open any panels that require the use of tools. 

 **WARNING:** Improper installation, operation, service or maintenance can cause property damage, injury or death. Read and understand these instructions thoroughly before positioning, installing, maintaining or servicing this equipment. 

**WARNING:** Keep the appliance free & clear of all combustible substances. If gas odor is detected at any time, immediately shut unit down at the main shutoff valve. Do not permit any open flames in the area of the appliance. Immediately contact an authorized Service Agency or your local Gas Supplier for service.

**WARNING:** Do not obstruct either the air inlet (underneath unit) or the ventilation air (back of unit). Provisions must be provided to provide an adequate air supply to the griddle.

**NOTICE:** The unit, when installed, must be electrically grounded and comply with local codes, or, in the absence of local codes, with the national electrical code ANSI/NFPA70-latest edition. Canadian installation must comply with CSA-STANDARD C.22.2 Number 0 M1982 General Requirements-Canadian Electrical Code Part II, 109-M1981-Commercial Cooking Appliances.

**NOTICE:** Local codes regarding installation vary greatly from one area to another. The National Fire Protection Association, Inc., states in its NFPA96 latest edition that local codes are "Authority Having Jurisdiction" when it comes to requirement for installation of equipment. Therefore, installation should comply with all local codes.

## SPECIFICATIONS AND DIMENSIONS

MODEL	WIDTH IN. (MM)	DEPTH IN. (MM)	HEIGHT IN. (MM)	# OF BURNERS	BTU/kW PER BURNER	TOTAL BTU/kW HOUR	W.C. IN. ('Mbar')
GGT-24	24 (610)	26 (661)	17-3/4(451)	2	25,000/7.3	50,000/14.6	6/10(15/25)
GGT-36	36 (915)	26 (661)	17-3/4(451)	3	37,500/11	75,000/22	6/10(15/25)
GGT-48	48 (1220)	26 (661)	17-3/4(451)	4	25,000/7.3	100,000/29.3	6/10(15/25)
GGM-24	24 (610)	26 (661)	16-3/4(426)	2	25,000/7.3	50,000/14.6	6/10(15/25)
GGM-36	36 (915)	26 (661)	16-3/4(426)	3	37,500/11	75,000/22	6/10(15/25)
GGM-48	48 (1220)	26 (661)	16-3/4(426)	4	25,000/7.3	100,000/29.3	6/10(15/25)

### Griddle Surface Dimensions

MODEL	WIDTH IN. (MM)	DEPTH IN. (MM)
GGT-24 and GGM-24	23 13/16"/ 605	19 1/2"/ 496
GGT-36 and GGM-36	35 13/16"/ 910	19 1/2"/ 496
GGT-48 and GGM-48	47 13/16"/ 1215	19 1/2"/ 496

## GENERAL INSTALLATION INSTRUCTIONS

Ensure gas supply and gas type, as shown on unit nameplate agree.

Unit installation must conform with the National Fuel Gas Code, ANSI Z223.1-1996, the National Gas Installation Code, CAN/CGA-B149.1, or the Propane Installation Code, CAN/CGA-B149.2 as applicable and in accordance with local codes.

Screw legs into the permanently fastened nuts on the four corners of the unit and tighten by hand. Level the unit by turning the adjustment screw at the bottom of each leg. Do not slide unit with legs mounted, lift if necessary to move unit.

Pipe threading compound must be resistant to the action of liquefied petroleum gases.

**Caution:** DO NOT use an open flame to check for leaks. Check all gas piping for leaks with a soap and water solution before operating unit.

**THESE UNITS ARE SUITABLE FOR INSTALLATION ON NON-COMBUSTIBLE SURFACES ONLY.**

Noncombustible clearances:

0" sides (0 mm)            6" rear (152 mm)

Do not obstruct the flow of combustion and ventilation air, under the unit by the legs or behind the unit by the flue.

Adequate clearance for air openings into the combustion chamber is required. Do not place objects between the bottom of the unit and the counter top.

There must be adequate clearance for removal of the front panel. All major parts except the burners are removable thru the front if the gas line is disconnected.

**European Community Installation Instructions:**

"THIS APPLIANCE MUST BE FITTED BY A COMPETENT PERSON. IN THE UK, CORGI REGISTERED INSTALLERS (INCLUDING THE REGIONS OF BRITISH GAS) UNDERTAKE TO WORK TO SAFE AND SATISFACTORY STANDARDS. THIS APPLIANCE MUST BE INSTALLED IN ACCORDANCE WITH THE GAS SAFETY (INSTALLATION AND USE) REGULATIONS AND THE RELEVANT BUILDING REGULATIONS / IEE. REGULATIONS. DETAILED RECOMMENDATIONS ARE CONTAINED IN THE FOLLOWING BRITISH STANDARD CODES OF PRACTICE - BS 6172, BS 5440 PART 2, BS 6891"

"THIS APPLIANCE MUST BE INSTALLED IN ACCORDANCE WITH THE RULES IN FORCE"

"MUST BE INSTALLED IN A WELL VENTILATED AREA. Ventilation requirements ie. B.S. 5440."

## **LIGHTING INSTRUCTIONS**

GGT and GGM Griddles are furnished with either a pilot safety valve or a standing pilot (not available in the European Community). Please follow the instructions for your unit.

### **Pilot Safety Valve Lighting Instructions**

1. Turn on main gas supply to unit, on-off valve located behind the unit (not supplied with unit).
2. Turn the burner control knobs to "OFF" position. Open the front panel and wait at least 5 minutes to allow any gas which may have accumulated in the firebox compartment to escape.
3. Depress red button on the pilot safety valve and light through observation hole in firebox. Keep red button on pilot safety depressed for at least 1 minute after pilot has lit. If pilot does not light, repeat this step.
4. To adjust the pilot flame, rotate knob next to the red button. Turning the knob clockwise increases the pilot flame. A properly sized pilot should be 1/2" to 3/4" long (12/19 mm).

### **Standing Pilot Lighting Instructions ( Not Available in the European Community )**

The pilot lights on the griddles have been set at the factory. A screwdriver maybe required for the first lighting to adjust the flame for your elevation.

1. Turn off the manual shut off valve and wait 5 minutes to clear the gas.
2. Turn all knobs to the "OFF" position.
3. Remove the grease drawer and front panel for easy access.
4. Turn the manual shut off valve on.
5. Hold an ignition source (match) at the pilot tube. When the flame is established, remove the ignition source.

6. Turn the burner knobs to "HI". If the burner does not ignite, promptly open the pilot valve more. If the pilot flame appears larger than necessary, turn it down and reset burner ignition. The pilot flame should be as small as possible but large enough to guarantee reliable ignition of the burners when the knobs are turned to "HI".
7. Replace the front panel and grease drawer.

### **Lighting main burner**

Since the burner is lit from constantly burning pilot, turn knobs to "HI" to put the unit in operation; then, adjust to any desired position between "LO" and "HI".

Main burner air supply:

1. For efficient burner operation, a proper balance of gas volume and primary air supply must be maintained which will result in complete combustion. Insufficient air supply results in a yellow streaming flame. Primary air supply is controlled by an air shutter on the front of the burner.
2. Loosen the screws on the front of the burner and adjust the air shutter to just eliminate the yellow tips of the burner flame. Lock the air shutter in place by tightening the screws.

### **European Community**

If adjustment becomes necessary in the field, it should be done by a factory authorized and trained technician who should seal the screw after the adjustment to safeguard against unauthorized tampering by the end user.

All burners are lit from constantly burning pilots. Turning the thermostat to the desired temperature is all that is required to put the unit in service.

Do not permit fans to blow directly at the unit. Wherever possible, avoid open windows next to the units' sides or back. Avoid wall type fans which create air cross-currents within a room.

It is also necessary that sufficient air should be allowed to enter the room to compensate for the amount of air removed by any ventilating system. Otherwise, a subnormal atmospheric pressure will occur, which will effect operation and cause undesirable working conditions.

A properly designed and installed hood will act as the heart of the ventilating system for the room or area in which the unit is installed and will leave the unit independent of changing draft conditions.

All valves and thermostats must be checked and lubricated periodically. Consult the authorized service representative in your area.

## **OPERATING INSTRUCTIONS**

### **Season Griddle:**

Heat to low temperature (300 - 350 F/150-180C) and pour on a small amount of cooking oil, about one ounce (30cc) per square foot of surface. Spread the oil over the entire griddle surface with a cloth to create a thin film. Wipe off any excess oil with a cloth. Repeat this procedure 2 to 3 times until the griddle has a slick, mirror-like surface.

### **Operation:**

Turn the burners on about 15-20 minutes before cooking for preheating. Set the knobs to the desired flame height or temperature. Each valve will control the gas flow to the burner to bring that area of the plate up to the set temperature. If different temperature settings are to be used, adjoining areas should be set at progressively higher temperatures using the lowest temperatures on the outside burners. A uniform and systematic approach to the loading of the griddle will produce the most consistent product results.

## CLEANING / MAINTENANCE

### Initial Cleaning:

Prior to operating your new griddle, thoroughly wash the griddle surface and the exterior with a mild detergent or soap solution. Do not use abrasive cleaners since this might damage the cabinet finish. If the stainless steel surfaces become discolored, scrub by rubbing only in the direction of the finished grain.

### Cleaning:

1. Always turn unit off and allow it to cool completely before cleaning. Clean thoroughly before first use.
2. After each use, clean the griddle with wire brush or flexible spatula.
3. Once a day, thoroughly clean splash back, sides and front. Remove the grease drawer, empty it and wash it out.
4. Once a week, clean the griddle surface thoroughly. If necessary, use a griddle stone, wire brush or steel wool on the surface. Rub with the grain of the metal while the griddle is still warm. A detergent may be used on the plate surface to help clean it; but, care must be taken to be sure the detergent is thoroughly removed. After removal of the detergent, the surface of the plate should then be covered with a thin film of oil to prevent rusting. Clean stainless surfaces with a damp cloth and polish with a soft dry cloth. To remove discoloration, use a nonabrasive cleaner. After each "weekly" cleaning, the griddle must be seasoned again. If the griddle usage is very high, the "weekly" cleaning procedures may be done more often than once a week.

### Extended Shutdown:

Turn the manual shutoff valve to "OFF"; (field installed valve not supplied by the manufacturer); turn all control knobs to the "OFF" position; and shut off the pilot flame by turning the adjustment on the pilot valve.

If the griddle is to be shut down for an extended period, put a heavy coat of grease over the griddle plate.

## SERVICE / REPAIR

**NOTE: THIS APPLIANCE MUST ONLY BE SERVICED BY AN AUTHORIZED AGENT.**

**NOTE:** Parts protected by the manufacturer or his agent are not to be adjusted by the installer unless the installer is an authorized service agent.

**If you have any questions or problems contact your nearest APW/Wyott Service Representative.**

### CONVERSION (Not Available in the European Community)

Instructions are for conversion from Natural Gas to Propane (L.P.) on all models GGT and GGM.

The conversion should be done before connecting the unit to the gas supply.

1. Remove the knobs and front panel.
2. Remove the supply tubes that go between the valves and the orifice fittings.
3. Remove the orifice fittings from the firebox. Change the orifices to the size recommended for propane (L.P.).
4. Replace the orifice fittings into the firebox.
5. Replace the supply tubes between the valves and the orifice fittings.
6. Replace the front panel, grease drawer and knobs.
7. Reverse plug in pressure regulator. The marking on the plug facing out should match gas supply.
8. Continue with the installation.

## Gas Valve Adjustment (Manual Valves):

The manual gas valve is at full on when turned counter-clockwise approximately 1/4 turn. This valve can be turned down to the point where the flame flickers over the burner but does not extinguish if temperatures below 300 degrees F are required.

Gas Valve Adjustment (BJWA Valves):

### By-Pass Adjustment Instructions:

1. Light burner, turn the dial to full on.
2. After 5 minutes, turn dial clockwise to a point slightly beyond the first mark on the dial.
3. With a screwdriver, turn the by-pass adjuster counter-clockwise to increase the flame, clockwise to decrease it, until there is a minimum flame over the entire burner. A flame height of between 3/16 and 1/4 inch tall is acceptable.
4. If the burners are turned to full on, the flame height should increase. Leave the flame at full on for a few minutes. Then, decrease the setting to low. The flame should decrease to the height that you just set.

**NOTE:** The regulating valve, with by-pass flame used on the GGT-style griddles, works best at temperatures above 300 degrees F. If you need temperatures below 300 deg. F, the by-pass flame can be turned off.

To turn off the by-pass flame, turn the adjuster screw clockwise until it meets resistance. **DO NOT OVER TIGHTEN.** The valve will still regulate the temperature with the by-pass turned off. **DO NOT TURN SCREW COUNTER-CLOCKWISE** more than one turn. Turning the adjuster screw to far counter-clockwise will allow a gas leak around the screw that will cause a fire hazard.

To Recalibrate the Griddle Control:

1. Recalibration should not be undertaken until the by-pass flame has been adjusted.
2. Light unit and set dial to the 350 degrees F. After the burner has been on about 15 minutes, check temperature. Continue to check the temperature at 5 minute intervals until 2 successive readings are within 5 degrees of each other. The control should be recalibrated if your readings are not within 10 degrees of the dial setting.
3. If recalibration is required, the additional steps to be taken are:
  - a. Remove the dial and D-stem. Push the calibration stem inward with a screwdriver, while holding the calibration stem firmly in, turn slowly clockwise to obtain a lower temperature or counter-clockwise for a higher temperature. Each mark on the retainer represents 25 degrees in temperature. Replace dial and D-stem.
  - b. Set dial at **400** degree mark. Check temperature again, as instructed above. If the temperature is not within 20 degrees of the dial setting (400 deg.), It means that the sensing element is inoperative and the control should be replaced.

**\*NOTE:** Turning the calibration stem to far will disassemble the inside of the valve. This negates the warranty.

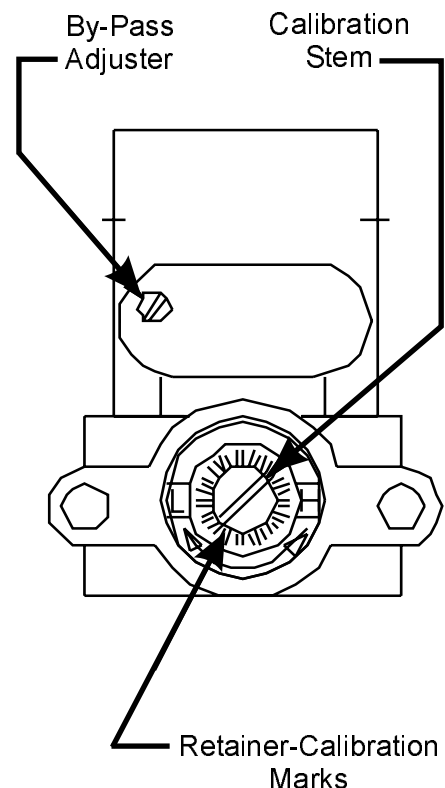

## TROUBLESHOOTING GUIDE

PROBLEM	POSSIBLE CAUSE
Heat does not come on when thermostat is turned on.	Thermostat is bad.
	Pilot burner not lit.
	Gas valve is bad.
Pilot burner will not light.	Obstructed pilot orifice.
	Pilot gas turned off at automatic pilot.
	Automatic pilot valve is bad.
Pilot burner will not stay lit.	Thermocouple is bad.
	Thermocouple is not hot enough.
	Obstructed or wrong size pilot orifice.
	Gas supply is not purged of air.
	Air is blowing pilot light out.
Fat appears to smoke excessively.	Heat is set too high.
	Moisture in the food may be turning into steam.
Food sticks to griddle.	Heat is set too high.
	Griddle surface needs cleaning and/or seasoning.
	Surface under food may not have been covered with enough cooking oil.
Food burned around edges or contains dark specks.	Heat is set too high.
	Griddle surface needs cleaning and/or seasoning.
	Surface under food may not have been covered with enough cooking oil.
Food is undercooked inside.	Heat is set too high.
	Food may not have been cooked for long enough time.
Food tastes greasy or has objectionable off-flavor.	Food itself may have off flavor.
	Food may have been stored improperly before cooking.
	Too much griddle fat used.
	Heat is set too low.
Noticeable build-up of gum on griddle.	Heat is set too high
	Griddle surface needs cleaning and/or seasoning.
	Too much griddle fat used.

PARTS LISTS & EXPLODED VIEWS

GGT GRIDDLES (EXPLODED VIEW)

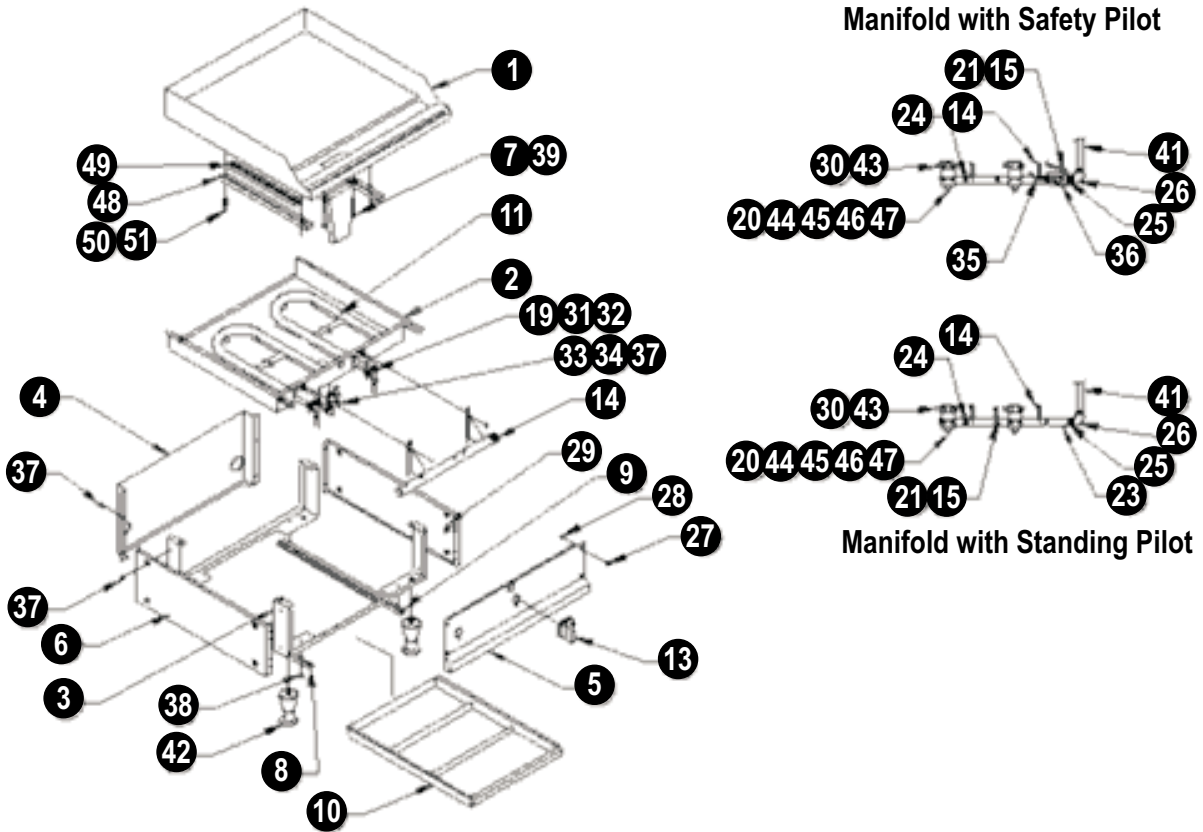

GGM GRIDDLES (EXPLODED VIEW)

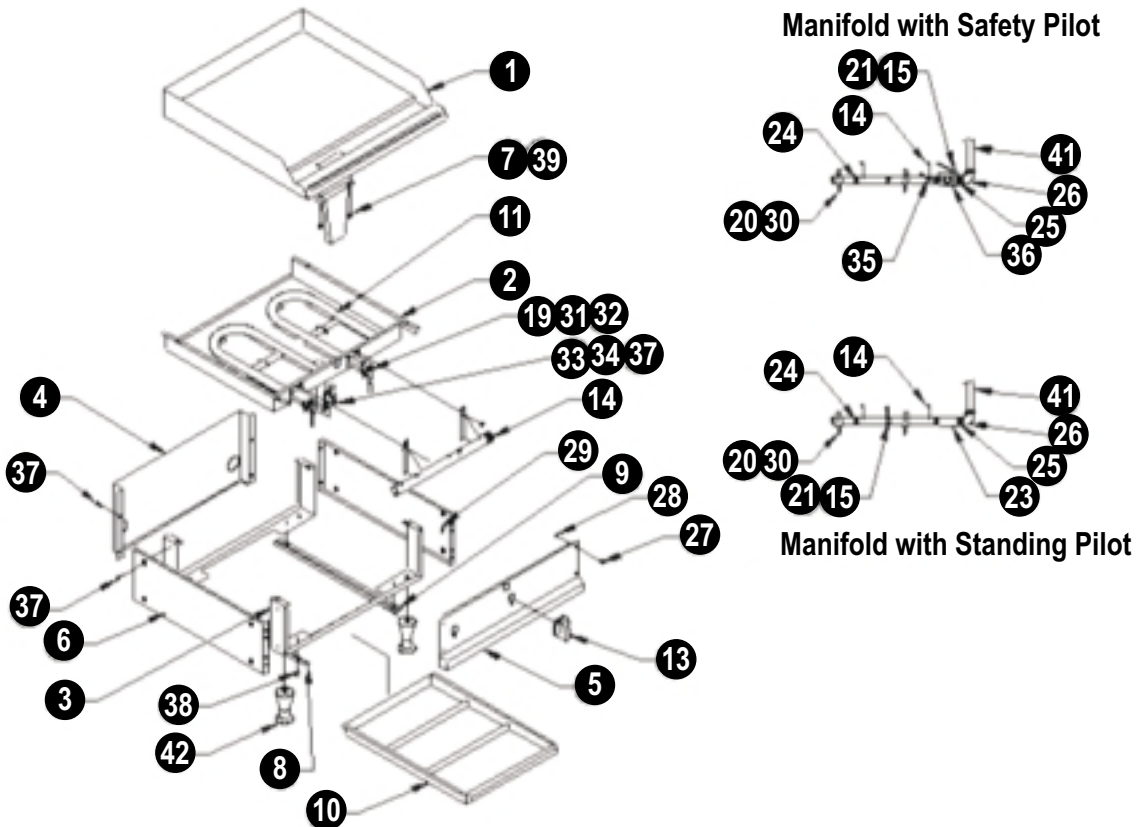

## GGT (PARTS LIST)

ITEM	DESCRIPTION	PART NO.	ITEM	DESCRIPTION	PART NO.
1	Griddle Weldment,	-24H 218140-37 -36H 218140-38 -48H 218140-39	20	BJWA Valve	20001-00
2	Firebox Weldment,	-24H 218140-20 -36H 218140-21 -48H 218140-22	21	Elbow, 1/4 CC x 1/8 NPT	20926-15
3	Leg Support,	-24H 218131-14 -36H 218132-14 -48H 218133-14	23	Coupling, 3/4 Pipe x 3"	20926-10
4	Back Panel,	-24H 218140-26 -36H 218140-27 -48H 218140-28	24	Plug, 1/8" Sq. Head	20925-17
5	Front Panel,	-24H 218140-23 -36H 218140-24 -48H 218140-25	25	Nipple, 3/4" Closed	20925-92
6	Body Side Panel	218133-13	26	Elbow, 3/4" Black Pipe	20926-11
7	Drip Trough Weldment	218140-56	27	Captive Screw	31007-24
8	Grease Tray Guide, R.H.	300475-08	28	Captive Screw Retainer	81966-02
9	Grease Tray Guide, L.H.	300475-07	29	Captive Screw Receptacle	81966-01
10	Grease Tray	218131-91	30	Elbow, 1/4 NPT x 3/8 CC	20931-03
11	Burner, U Shape	20658-50	31	Elbow, 3/8-27 M x 3/8 CC	20926-14
	Burner, S Shape	20658-55	32	Bracket, Orifice Mount	218140-19
13	Knob	87056-00	33	Bracket, Pilot Mount	218140-36
14	Manifold Weld.,	-24H 218140-29 -36H 218140-30 -48H, 1 ea. 218140-31 -48H, 1 ea. 218140-29	34	Pilot Burner	20928-00
15	Pilot Tube, Standing Pilot	218140-45		Pilot Orifice, Natural	20929-03
16	Safety Pilot Tube	-24 & -48 218140-47 -36 218140-48		Pilot Orifice, L. P.	20929-02
17	Supply Tube, to Orifice	218140-43	35	Thermocouple	14731-03
18	Pressure Regulator, Conv.	20666-00	36	Safety Pilot Valve	20927-02
19	Nat. Orifice, #44 @	-24, -48 20668-44	37	Screw, #10-32 x 1/2"	81707-00
	Nat. Orifice, #37 @	-36 20668-37	38	Screw, #8-32 x 3/8"	81531-00
	L.P. Orifice, #54 @	-24, -48 20668-54	39	Nut, #10-32	84171-00
	L.P. Orifice, #50 @	-36 20668-50	41	Pipe, 3/4 Black x 23" Long	20926-13
			42	4" Adjustable Leg	86320-00
			43	Plug, 1/4 NPT	20925-53
			44	Mounting Flange	20001-01
			45	"D" Stem	20001-02
			46	Screw, #10-24 x 1"	81854-00
			47	Washer, Lock #10	85117-00
			48	Thermostat Bulb Cover	217230-90
			49	Thermostat Bulb Insulation	10180-44
			50	Washer, Flat 5/16"	85093-00
			51	Nut, 5/16-18 Hex	84362-00

## GGM (PARTS LIST)

ITEM	DESCRIPTION	PART NO.	ITEM	DESCRIPTION	PART NO.
1	Griddle Weldment,	-24H 218140-37 -36H 218140-38 -48H 218140-39	20	On-Off Valve	20680-00
2	Firebox Weldment,	-24H 218140-20 -36H 218140-21 -48H 218140-22	21	Elbow, 1/4 CC x 1/8 NPT	20926-15
3	Leg Support,	-24H 218131-14 -36H 218132-14 -48H 218133-14	23	Coupling, 3/4 Pipe x 3"	20926-10
4	Back Panel,	-24H 218140-26 -36H 218140-27 -48H 218140-28	24	Plug, 1/8" Sq. Head	20925-17
5	Front Panel,	-24H 218140-23 -36H 218140-24 -48H 218140-25	25	Nipple, 3/4" Closed	20925-92
6	Body Side Panel	218133-13	26	Elbow, 3/4" Black Pipe	20926-11
7	Drip Trough Weldment	218140-56	27	Captive Screw	31007-24
8	Grease Tray Guide, R.H.	300475-08	28	Captive Screw Retainer	81966-02
9	Grease Tray Guide, L.H.	300475-07	29	Captive Screw Receptacle	81966-01
10	Grease Tray	218131-91	30	Elbow, 3/8-27 F x 3/8 CC	20926-12
11	Burner, U Shape	20658-50	31	Elbow, 3/8-27 M x 3/8 CC	20926-14
	Burner, S Shape	20658-55	32	Bracket, Orifice Mount	218140-19
13	Knob	87056-00	33	Bracket, Pilot Mount	218140-36
14	Manifold Weld.,	-24H 218140-29 -36H 218140-30 -48H, 1 ea. 218140-31 -48H, 1 ea. 218140-29	34	Pilot Burner	20928-00
15	Pilot Tube, Standing Pilot	218140-45		Pilot Orifice, Natural	20929-03
16	Safety Pilot Tube	-24 & -48 218140-47 -36 218140-48		Pilot Orifice, L. P.	20929-02
17	Supply Tube, to Orifice	218140-43	35	Thermocouple	14731-03
18	Pressure Regulator, Conv.	20666-00	36	Safety Pilot Valve	20927-02
19	Nat. Orifice, #44 @	-24, -48 20668-44	37	Screw, #10-32 x 1/2"	81707-00
	Nat. Orifice, #37 @	-36 20668-37	38	Screw, #8-32 x 3/8"	81531-00
	L.P. Orifice, #54 @	-24, -48 20668-54	39	Nut, #10-32	84171-00
	L.P. Orifice, #50 @	-36 20668-50	41	Pipe, 3/4 Black x 23" Long	20926-13
			42	4" Adjustable Leg	86320-00
			43	Plug, 1/4 NPT	20925-53
			44	Mounting Flange	20001-01
			45	"D" Stem	20001-02
			46	Screw, #10-24 x 1"	81854-00
			47	Washer, Lock #10	85117-00
			48	Thermostat Bulb Cover	217230-90
			49	Thermostat Bulb Insulation	10180-44
			50	Washer, Flat 5/16"	85093-00
			51	Nut, 5/16-18 Hex	84362-00

## APW WYOTT EQUIPMENT LIMITED WARRANTY

APW Wyott Foodservice Equipment Company warrants its equipment against defects in materials and workmanship, subject to the following conditions:

This warranty applies to the original owner only and is not assignable.

Should any product fail to function in its intended manner under normal use within the limits defined in this warranty, at the option of APW Wyott such product will be repaired or replaced by APW Wyott or its Authorized Service Agency. APW Wyott will only be responsible for charges incurred or service performed by its Authorized Service Agencies. The use of other than APW Wyott Authorized Service Agencies will void this warranty and APW Wyott will not be responsible for such work or any charges associated with same. The closest APW Wyott Authorized Service Agent must be used.

This warranty covers products shipped into the 48 contiguous United States, Hawaii, metropolitan areas of Alaska and Canada. There will be no labor coverage for equipment located on any island not connected by roadway to the mainland.

Warranty coverage on products used outside the 48 contiguous United States, Hawaii, and metropolitan areas of Alaska and Canada may vary. Contact the international APW Wyott distributor, dealer, or service agency for details.

### Time Period

One year for parts and one year for labor, effective from the date of purchase by the original owner. The Authorized Service Agency may, at their option, require proof of purchase. Parts replaced under this warranty are warranted for the un-expired portion of the original product warranty only.

### Exceptions

- \***Gas/Electric Cookline:** Models GCB, GCRB, GF, GGM, GGT, CHP-H, EF, EG, EHP. Three (3) Year Warranty on all component parts, except switches and thermostats. (2 additional years on parts only. No labor on second or third year.)
- \***Broiler Briquettes, Rock Grates, Cooking Grates, Burner Shields, Fireboxes:** 90 Day Material Only. No Labor.
- \***Heat Strips:** Models FD, FDL, FDD, FDDL. Two (2) Year Warranty on element only. No labor second year.
- \***Glass Windows, Doors, Seals, Rubber Seals, Light Bulbs:** 90 Day Material Only. No Labor.

In all cases, parts covered by extended warranty will be shipped FOB the factory after the first year.

### Portable Carry In Products

Equipment weighing over 70 pounds or permanently installed will be serviced on-site as per the terms of this warranty. Equipment weighing 70 pounds or under, and which is not permanently installed, i.e. with cord and plug, is considered portable and is subject to the following warranty handling limitations. If portable equipment fails to operate in its intended manner on the first day of connection, or use, at APW Wyott's option or its Authorized Service Agency, it will be serviced on site or replaced.

From day two through the conclusion of this warranty period, portable units must be taken to or sent prepaid to the APW Wyott Authorized Service Agency for in-warranty repairs. No mileage or travel charges are allowed on portable units after the first day of use. If the customer wants on-site service, they may receive same by paying the travel and mileage charges. Exceptions to this rule: (1) countertop warmers and cookers, which are covered under the Enhanced Warranty Program, and (2) toasters or roller grills which have in store service.

### Exclusions

The following conditions are not covered by warranty:

- \*Equipment failure relating to improper installation, improper utility connection or supply and problems due to ventilation.
- \*Equipment that has not been properly maintained, calibration of controls, adjustments, damage from improper cleaning and water damage to controls.
- \*Equipment that has not been used in an appropriate manner, or has been subject to misuse or misapplication, neglect, abuse, accident, alteration, negligence, damage during transit, delivery or installation, fire, flood, riot or act of god.
- \*Equipment that has the model number or serial number removed or altered.

If the equipment has been changed, altered, modified or repaired by other than an Authorized Service Agency during or after the warranty period, then the manufacturer shall not be liable for any damages to any person or to any property, which may result from the use of the equipment thereafter.

This warranty does not cover services performed at overtime or premium labor rates. Should service be required at times which normally involve overtime or premium labor rates, the owner shall be charged for the difference between normal service rates and such premium rates. APW Wyott does not assume any liability for extended delays in replacing or repairing any items beyond its control.

In all cases, the use of other than APW Wyott Authorized OEM Replacement Parts will void this warranty.

This equipment is intended for commercial use only. Warranty is void if equipment is installed in other than commercial application.

### Water Quality Requirements

Water supply intended for a unit that has in excess of 3.0 grains of hardness per gallon (GPG) must be treated or softened before being used. Water containing over 3.0 GPG will decrease the efficiency and reduce the operation life of the unit.

**Note: Product failure caused by liming or sediment buildup is not covered under warranty.**

**"THE FOREGOING WARRANTY IS IN LIEU OF ANY AND ALL OTHER WARRANTIES EXPRESSED OR IMPLIED INCLUDING ANY IMPLIED WARRANTY OF MERCHANTABILITY OR FITNESS FOR PARTICULAR PURPOSES AND CONSTITUTES THE ENTIRE LIABILITY OF APW WYOTT. IN NO EVENT DOES THE LIMITED WARRANTY EXTEND BEYOND THE TERMS STATED HEREIN."**

9/05