

PRODUCT:

QUANTITY:

ITEM #:

## Designed Smart

- Heavy-duty top mount insulated round drop-in food well designed for installation in metal, or wood countertop if optional wood mounting kit is provided.
- Hot Food Well is designed to accommodate a 11 qt. round inset.
- The CH-11D is suitable for wet operation only.
- Standard EZ lock reduces installation time.
- Large indicating pilot light.
- Immersible heating element provides quick recovery.

## Built Solid

- 20 ga. deep-drawn stainless steel well pans.
- The units are standard with complete UL construction including electrical conduit, bezel, and control box.
- Stainless steel drain coupling.
- Thermostatic control with 36" capillary (effective length 26").
- Compact housing - overall depth 9 1/4".
- Multiple units can be installed in same table or counter.

## Reliability backed by APW Wyott's Warranty

- All APW Wyott food wells are backed by a 1-year parts and labor warranty, including on-site service calls within 50 miles of authorized service technicians.
- Certified by the following agencies:



Top Mount Round Well w/ Immersible Element

## Options

- Wood mount kit 11 qt. (55323)
- Drain kit plus shut off valve (56420)
- Electrical code kit - 72" includes bezel, conduit, junction box (55347)
- Lever operated shut-off valve (56360)

See reverse side for product specifications.

PRODUCT:

QUANTITY:

ITEM #:

**Round Wells Hot Food Wells**

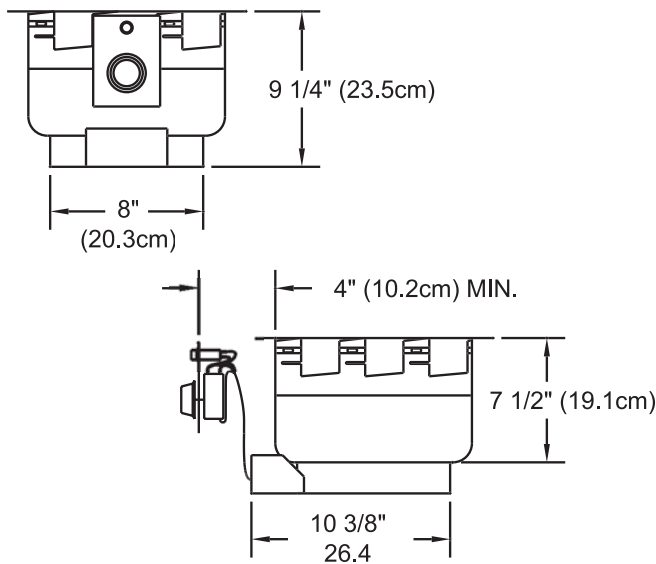
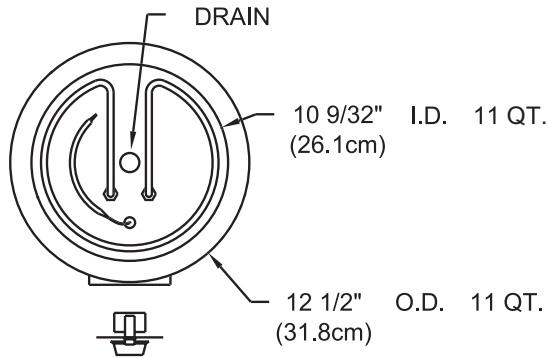

**PRODUCT SPECIFICATIONS**

**Construction:**

Well is constructed of one piece die-stamped 20 ga., Type 304 stainless steel. Stainless steel 1/2" NPT drain welded to bottom of pan provided with removable screen. Unit is heated by a tubular immersible calrod heating element. Unit standard with APW Wyott E-Z Locks for easy installation. 1" (2.5 cm) flange. Thermostatic control has 36" capillary (effective length 26").

**Electrical Specifications:**

120V, 1650W, 13.75Amps

**Overall Dimensions:**

**Outside:** 12-1/2" Dia. x 9-1/4" D  
(31.8 cm x 23.5 cm)

**Inside:** 10-9/32" Dia. x 7-1/2" D  
(26.1 cm x 19.1 cm)

**Cutout:** 10-3/4" Dia.  
(27.3 cm)

**Wood Mount**

**Kit Cutout:** 12-13/16" Square (34.9 cm)

**Control Cutout:** 5-3/4"W x 6-1/4"H  
(27.3cm x 15.9 cm)

**Shipping Information:**

**Weight:** 12 lbs. (5.5 kg)

F.O.B. / Dallas, TX 75226

*\*APW Wyott reserves the right to modify specifications or discontinue models without incurring obligation.*