

PRODUCT:

QUANTITY:

ITEM #:

Designed Smart

Compact Design With High Output

- Fits in tight counter space and is available in 15lb capacity
- Reaches frying temperatures fast, and maintains heat levels from one load to next
- Cooks 30 lbs of potatoes in 1 hour

Easy to Operate

- Cycling light alerts operator that unit is ready for next batch of fries.
- Unit automatically shuts down if frying compound overheats.
- Stainless steel exterior is easy to wipe clean.

**EF-15N Countertop Electric Fryer**

Built Solid

Built to Last!

- Thick, stainless steel construction

Reliability backed by APW Wyott's Warranty

- APW Wyott cooking equipment is backed by a 1-year limited warranty, and a 1-year on-site labor warranty.
- Certified by the following agencies:



APW Wyott Design Features

- Stainless steel construction.
- 4" (10 cm) legs.
- Front panel permits easy servicing.
- Lift-out, one piece tank with carrying handles. Large foaming area above frying compound level.
- Insulating air pocket surrounds tank for improved temperature control.
- Swing up, pyrolytic heating elements with two-stage locking mechanism.
- Cold zone under heating elements reduces circulation of particles in frying compound.
- Front-located adjustable thermostat (200°F / 93°C to 400°F / 204°C) with on/off switch.
- High-limit protection control circuit breaker which automatically trips should frying compound overheat.
- High temperature 392°F (200°C) internal wiring.
- Nickel-plated twin fry baskets with front hangers.

See reverse side for product specifications.

PRODUCT:

QUANTITY:

ITEM #:

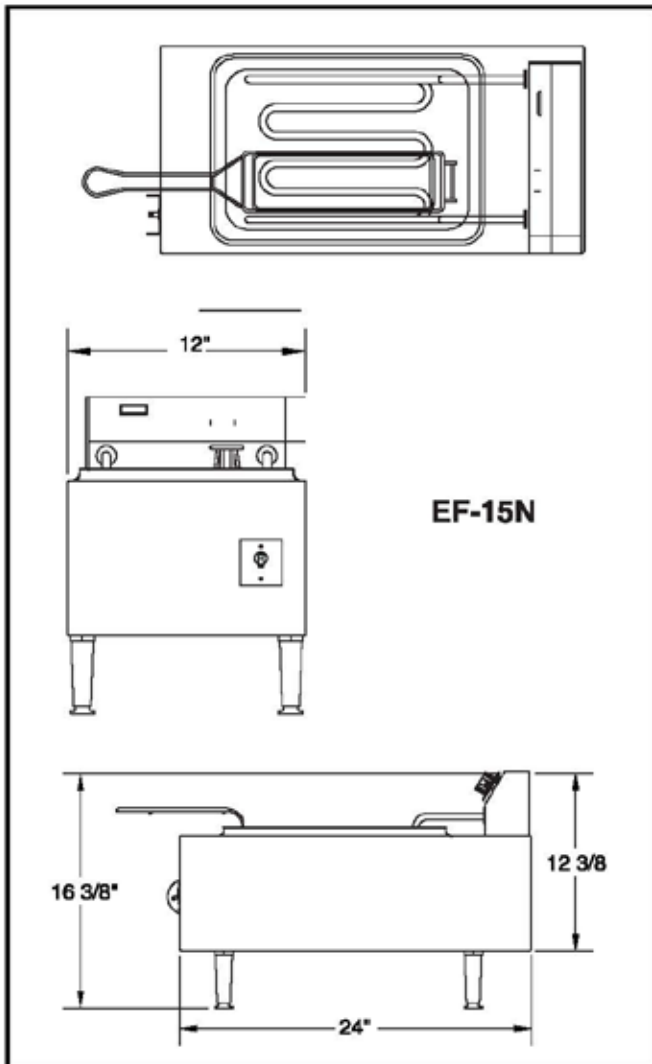
**PRODUCT SPECIFICATIONS****Construction:**

Heavy-duty stainless steel body. Fry baskets are constructed of nickel-plated steel. 4" adjustable chrome legs.

Electrical Information:

Units are wired for hard wiring in the field.

Electrical Specifications:

EF-15N: 208/240V, 5.74/4.28W, 23.8/20.6Amps

Capacity:

EF-15N: 15 lbs. (6.8kg)

Basket Size:

2 Half Size 6.9" H x 3.5" W x 11.4" D

Overall Dimensions:

EF-15N: 16 3/8" H x 12" W x 24" D
(41.6 cm x 30.5 cm x 61 cm)

Shipping:

EF-15N: 36 lbs. (16.32 kg)

Freight Class: 85

FOB: Cheyenne, WY

*APW Wyott reserves the right to modify specifications or discontinue models without incurring obligation.