

PRODUCT

QUANTITY:

ITEM#:

Designed Smart.

Developed for high output

- The APW Wyott M-2000 Bun Grill can generate up to 1100 Bun Halves per hour.
- Bun Grill is available with extended Super Feeder to allow for high volume production.
- Fast heat-up allows your operation to react to surges in volume.
- Constructed with a special element embedded into the griddle plate to produce the most efficient heat.

Perfectly Caramelized Buns all the time

- Patented "self-leveling" conveyor automatically adjusts to various sizes of buns, bagels, and Texas Toast.
- Butter roller and pan consistently covers buns with the perfect amount of butter.
- Durable nickel plated cast aluminum griddle plate is controlled with a solid state thermostat adjustable to temperatures between 200 and 575 degrees.

Easy to Maintain and Service

- Removable Side panel allows easy access for service.
- Front Panel is easy to remove. Conveyor belt lifts out for easy cleaning. Allows direct access to clean griddle surface.

Built Solid.

Built to Last

- Stainless Steel construction protects against kitchen 'wear and tear' and rust.
- High Heat insulated wire is used for long life.

Easy to fit into all Counter Spaces

- Compact, vertical design allows unit to fit into tight counter areas.

Reliability Backed By APW Wyott's Warranty

- APW Wyott's Bun grills are backed by a 1 year Parts and Labor warranty, including On-Site Service calls within 50 miles of authorized service technicians.
- Will be certified by the following agencies:



SANITATION CLASSIFIED



(Pan not included)

MODEL M-2000 Bun Grill Toaster

Bun Grill is the fastest Bun Toaster in the industry:

- Initial Bun placed in the Toaster is perfectly Caramelized in 17-18 seconds.
- Continuously feeding buns in the the top slot will result in toasted bun every 6-7 seconds.

APW Wyott Design Features

- Heavy-duty stainless steel construction.
- Snap on superfeeder.
- Butter wheel and pan. (optional)
- Patented self-leveling conveyor automatically adjusts to various sizes of buns, bagels and Texas Toast.
- Fast Warm-up.
- Permanent grill surface.
- Use wet or dry (dry requires Teflon sheet).
- Compact vertical style saves space.
- Fast – grills up to 1100 pieces per hour.
- Caramelized bun surface – buns never get soggy.
- 4" Adjustable legs.

Options

- Teflon Sheet Kit (1) sheet
- Butter wheel and pan

See Reverse Side for product specifications

PRODUCT:

QUANTITY:

ITEM#:

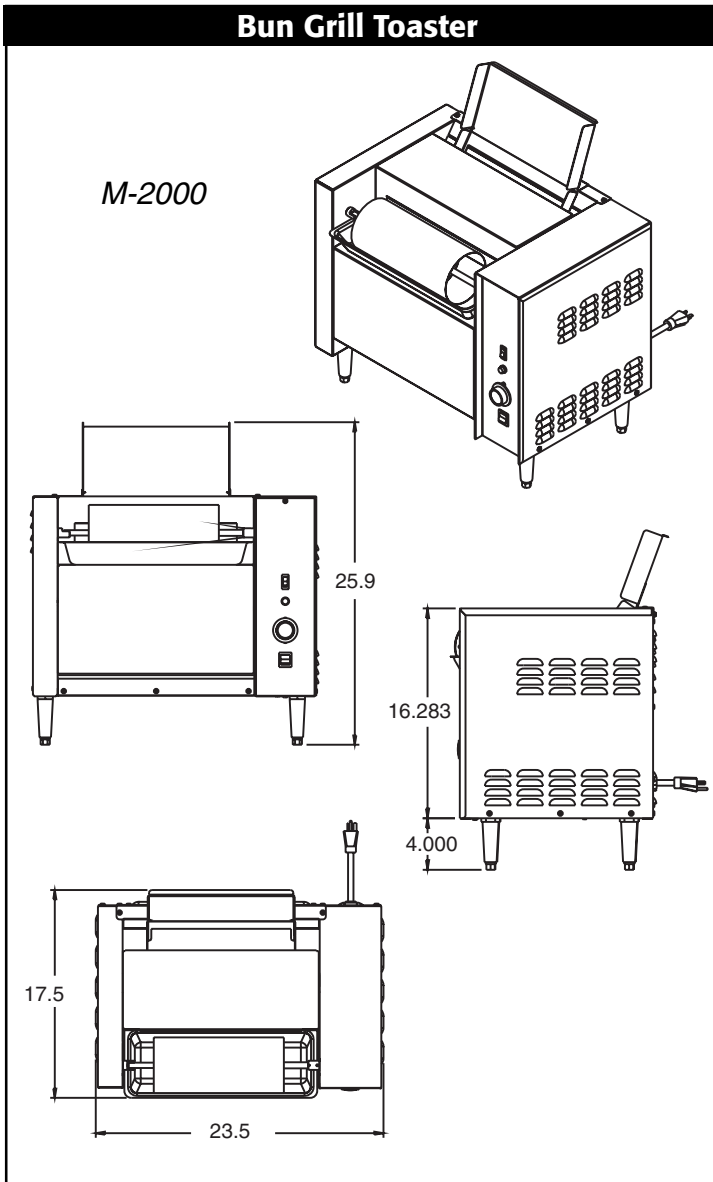

Model M-2000 Bun Grill Toaster

PRODUCT SPECIFICATIONS

Construction:

Heavy-duty stainless steel construction. Nickel plated cast aluminum griddle plate. Four inch chrome legs.

Electrical Information:

Each unit is equipped with a 39", three wire grounded power cord which terminates with a standard three-pronged male plug. The 208/240V units use a NEMA 6-20P plug.

Electrical Specifications:

M-2000: 208V, 2880W, 13.8Amps
240V, 3840W, 16Amps

Capacity:

M-2000: Up to 1600 pieces per hour.

Overall Dimensions:

M-2000: 25.9" H x 23.5" W x 17.5" D
(65.8 cm x 59.7 cm x 44.4 cm)

Shipping Weight:

100 lbs. (45kg)
F.O.B. Dallas, TX



Easy to clean
and service.

World Class Support

World Class Sales Support to assist you with finding the right solution to your operation's needs. Call Customer Service at 1-800-527-2100 or Fax your request to 1-214-565-0976.

For more information about APW Wyott's World Class Support and High Performance Equipment, look us up on the Internet at www.APWwyott.com

Most Extensive Service System in the Industry! Wyott has three levels of service support for your needs:

- Direct Service Hot Line to Service Department, call 1-800-527-2100.
- To find the Registered Service Technician in your area, call Automated Service Hot Line at 1-800-733-2203.
- National Service Cooperative®, call 1-800-298-1862.