

PRODUCT: _____ QUANTITY: _____ ITEM #: _____

Tough & Compact

- Cast-iron grill plates
- 14"x14" work surface with even heat distribution
- Rapid grilling with powerful 3.6KW heating elements
- Top and bottom heat controlled separately
- Thermostatically controlled up to 570°F
- Adjustable spring counter balanced top
- Removable stainless steel side utensil shelves
- Heavy duty stainless steel base for lasting service
- Manual Timer

**RGX-SERIES**

Accessories

- Detachable 2-position front drip tray and
- Scraper and Brush for ease of cleaning

Tough & Compact

Reliability backed by APW Wyott's Warranty

- All APW Wyott Rhino Grills are backed by a 1-year parts and labor warranty, including on-site service calls within 50 miles of authorized service technicians.
- Certified by the following agencies



See reverse side for product specifications.

PRODUCT:

QUANTITY:

ITEM #:

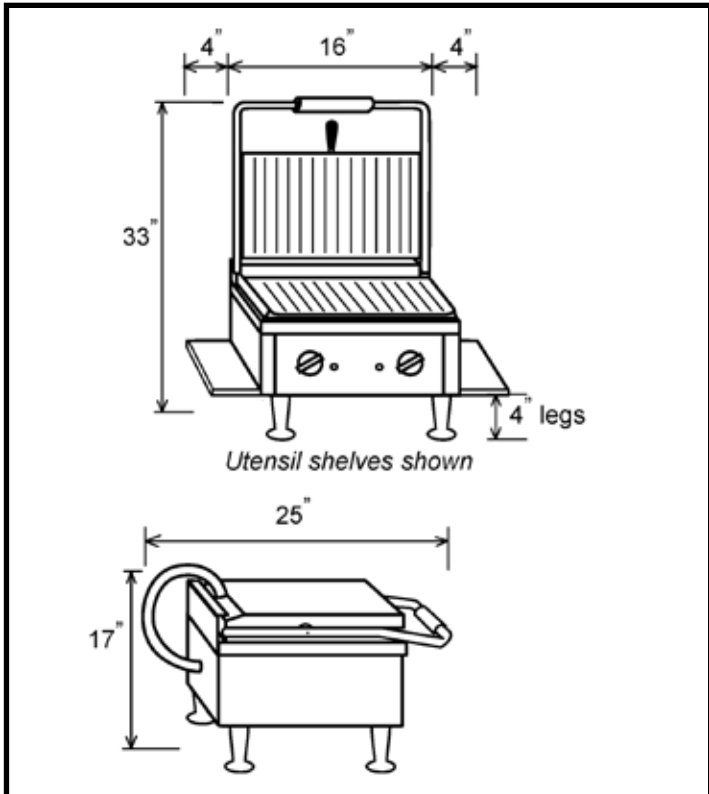

Construction:

Stainless steel built. Installation clearance: minimum of 4" To combustible surfaces from body (zero clearance from utensil shelves)

Electrical Information:

The 208V, 240V, and 230V all use a NEMA 6-20P.

Electrical Specifications:

RGX Series

208/240V, 1PH 3.6KW, 13/15

Amps

Bottom heat only

2.2KW, 8/10 Amps

Capacity:

Up to 300 pieces per hour.

Overall Dimensions:

24"Wx25"Dx33"H including 4" legs & 2 4" side utensil shelves)

Work Surface:

14"Wx14"D

Shipping:

100 lbs

Freight Class 100

FOB: Dallas, TX

CONTROL PANEL:

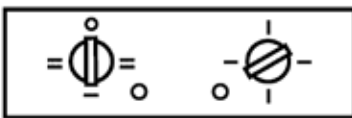

Standard: Mode selector switch, regulating thermostat, green and red pilot lights

