



Uninsulated Hot Food Wells Bottom Mount Series

Models: BM-30 BM-30D BM-30-UL BM-30D-UL ("D" designates drain)

PRODUCT:

QUANTITY:

ITEM #:

Designed Smart

- Heavy-duty bottom mount, Uninsulated Rectangular Drop-in Hot Food Well is designed for installation in metal countertop.
- Hot Food Well accommodates standard size steamtable pans, in conjunction with fabricated counter.
- Unit is heated by tubular calrod heat element shaped in serpentine fashion for even heat distribution to pan base.
- Thermostatically controlled for fast heat recovery.

Built Solid

- Well is constructed of deep-drawn, 20 ga., Type 304, stainless steel.
- Units shipped with drain are provided with stainless steel 1/2 NPT drain welded to bottom of pan and provided with removable screen.
- Element mounted under well and secured by aluminized deflector shield for maximum efficiency.
- The units are available in a UL Recognized component construction with open wires and increase-decrease plate or complete UL Listed construction including electrical conduit, bezel and control box.

Reliability backed by APW Wyott's Warranty

- All APW Wyott food wells are backed by a 1-year parts and labor warranty, including on-site service calls within 50 miles of authorized service technicians.
- Certified by the following agencies:



Uninsulated Bottom Mount Hot Food Well BM-30-UL

APW Wyott Design Features

- 20 ga. deep-drawn stainless steel well pans.
- Available with or without drain.
- Unit may be used wet or dry (wet use offers best results).
- Easy access to heating elements.
- Thermostatic control with 36" capillary (effective length 26").
- Large indicating pilot light.
- Multiple units can be installed in same table or counter.
- Multiple wattage and voltage choices

Options

- Thermostat with 72" capillary (effective length 62")
- Recessed bezel (56370)
- Drain kit (56420)
- Lever operated shut off valve (56360)
- Infinite Controls
- Square corners (BM-30C)

See reverse side for product specifications.



APW Wyott Foodservice Equipment Company · 729 Third Ave., Dallas, TX 75226
(800) 527-2100 · (214) 421-7366 · Fax (214) 565-0976 · www.apwwyott.com · info@apwwyott.com

Rev. 6/07/2005



Uninsulated Hot Food Wells Bottom Mount Series

Models: BM-30 BM-30D BM-30-UL BM-30D-UL ("D" designates drain)

PRODUCT:

QUANTITY:

ITEM #:

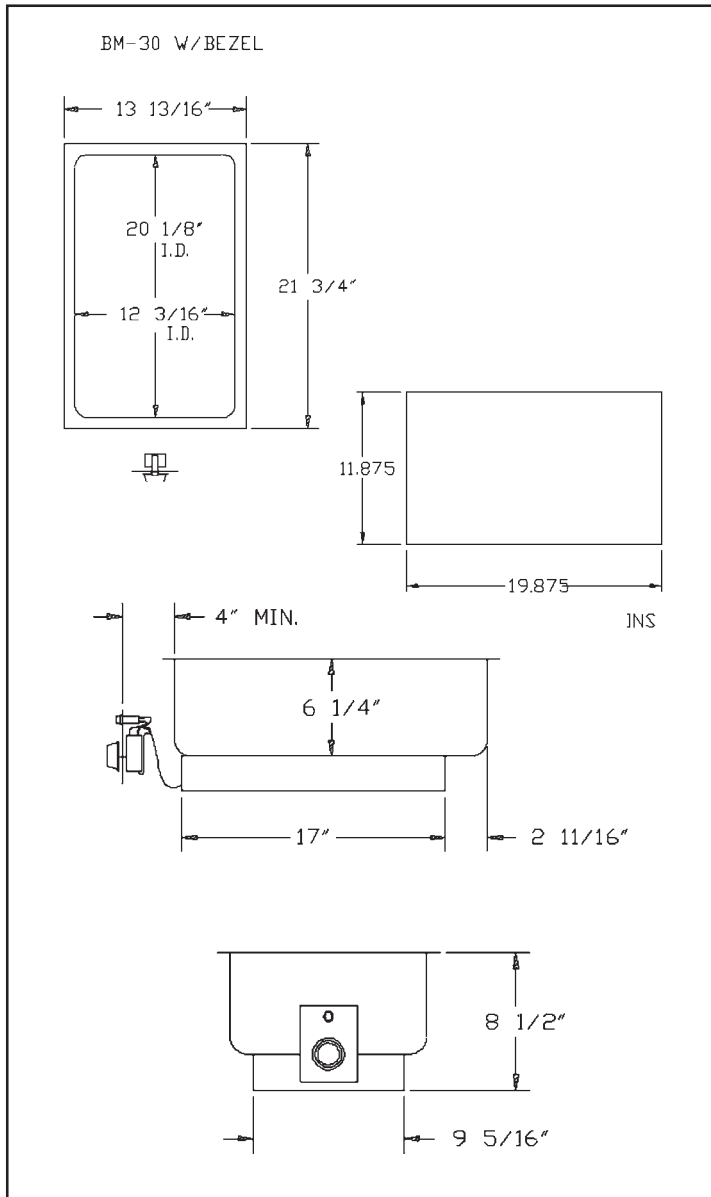

PRODUCT SPECIFICATIONS

Construction:

Well is constructed of pressed 304 stainless steel, 6 1/4" deep in the interior. Aluminized steel reflector pan. Units shipped with drain are provided with stainless steel 1/2" NPT drain welded to bottom of pan. 13/16" flange. Recommended flange turndown 3/4". 4 round corners; 1" radiused. Thermostatic control has 36" capillary (effective length 26"). UL Models: bezel size 6-1/4"W x 6-7/8" H. Bezel cutout 5-3/4"W x 6-1/4" H. UL models control use increase/decrease plate hole pattern.

Electrical Specifications:

120V, 750W, 6.25 Amps
120V, 1200W, 10 Amps
208V, 1600W, 7.7 Amps
208/240V, 1200/1600W, 5.8/6.7 Amps
208/240/277V, 900/1200/1600W, 4.3/5.0/5.8 Amps

Overall Dimensions:

Outside	8 1/2" H x 13 3/16" W x 21 3/4" D (15.9 cm x 35.1 cm x 55.2 cm)
Inside	6 1/4" H x 12 3/16" W x 20 1/8" D (21.6 cm x 31.1 cm x 51.1 cm)
Cutout	11 7/8" W x 19 7/8" D (30.2 cm x 50.5 cm)

Shipping Information:

Weight	23 lbs. (10.4 kg) UL
	20 lbs. (9.1 kg) Non-UL

F.O.B. Dallas, TX 75226

*APW Wyott reserves the right to modify specifications or discontinue models without incurring obligation.



APW Wyott Foodservice Equipment Company · 729 Third Ave., Dallas, TX 75226
(800) 527-2100 · (214) 421-7366 · Fax (214) 565-0976 · www.apwwyott.com · info@apwwyott.com

Rev. 6/7/2005
1408